

PLEASE NOTE TILT AND PAN ANGLES ARE DEPENDANT ON SCREEN SIZE

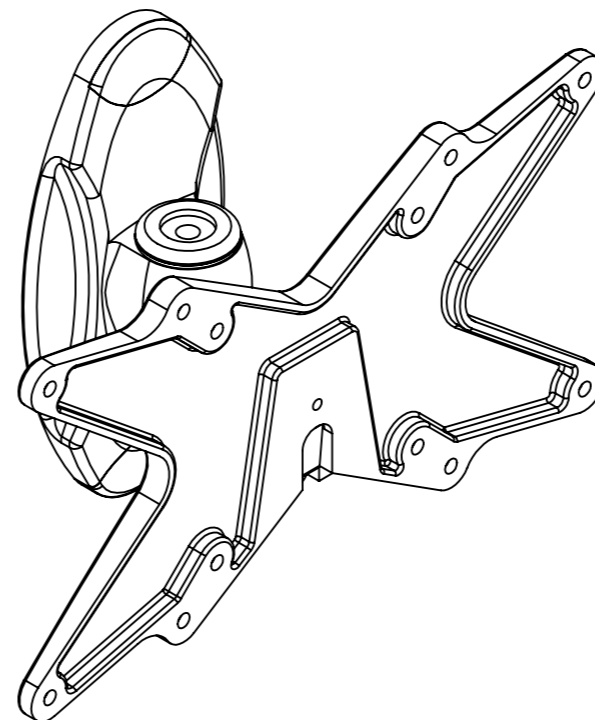
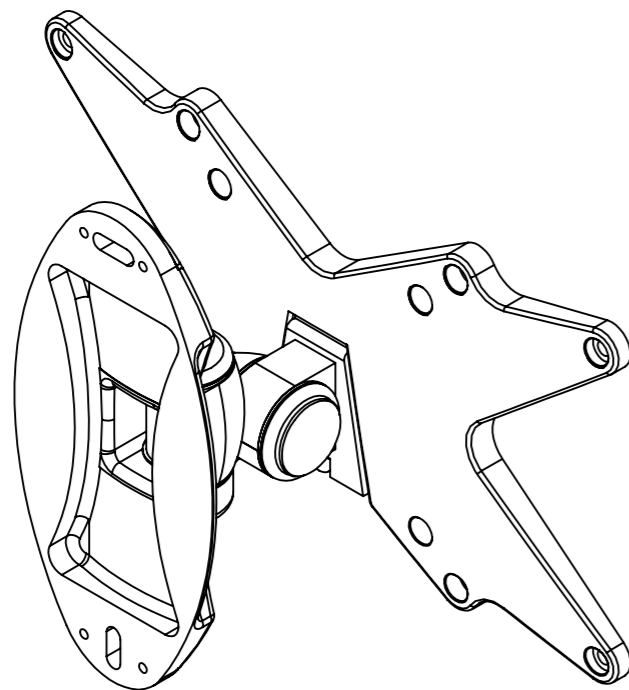
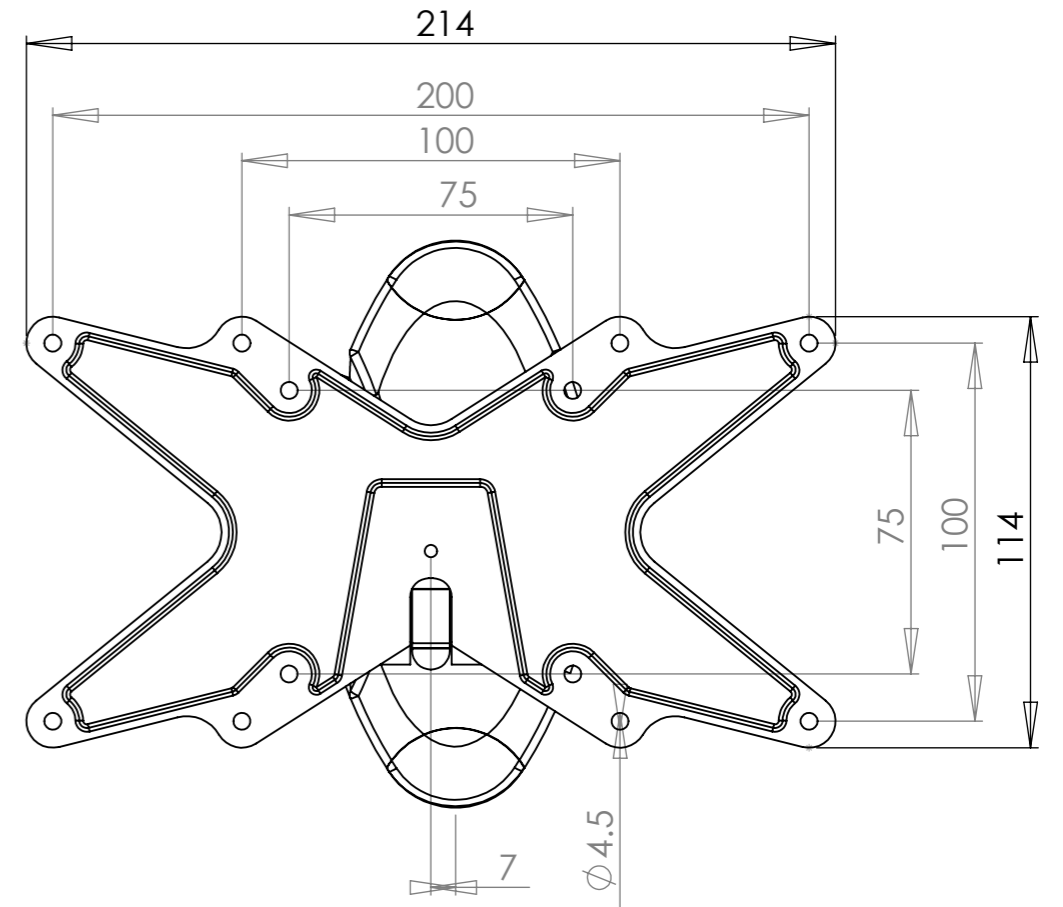
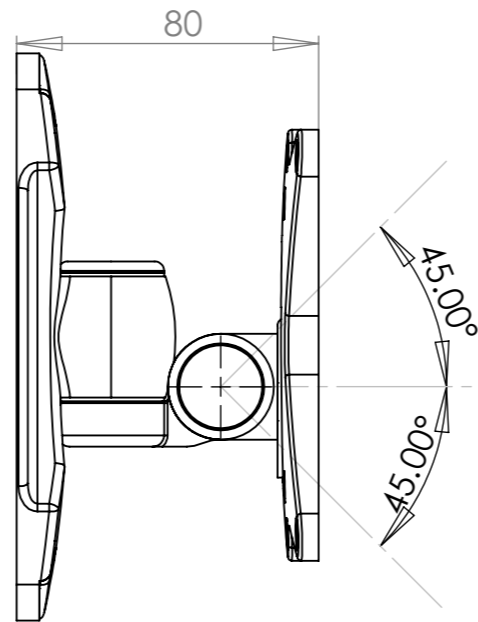
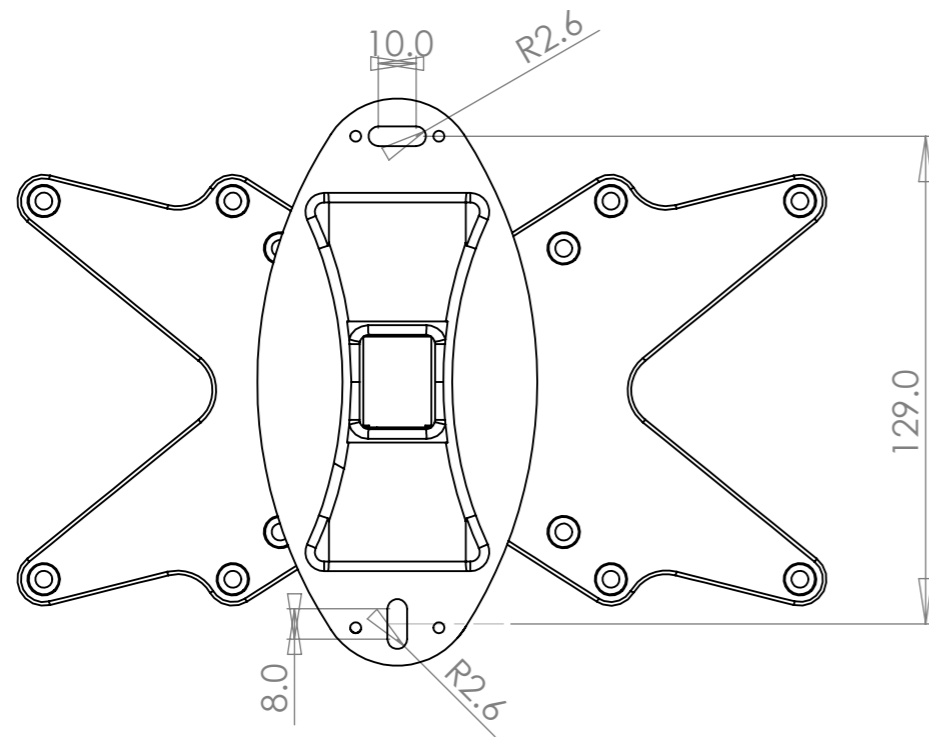

MAX LOAD RATING = 18kg
 SCREEN TO SCREEN CASTING FIXINGS = M4
 WALL TO WALL BRACKET FIXINGS = MIN M5

DEBUR AND BREAK SHARP EDGES		Mode-AL.com	
MATERIAL: ALUMINUM		UNIT 4 ANAMAX IND. PARK, OXFORD ROAD, TATLING END, BUCKS SL9 7BB TEL +44 (0)1753 880824	
FINISH: SILVER		TITLE: VESA 200X200 PAN TILT	
UNLESS OTHERWISE SPECIFIED: DIMENSIONS ARE IN MILLIMETERS TOLERANCES: LINEAR: X. ±1.0mm X.X ±0.25 mm X.XX ±0.10 mm ANGULAR: X.XX ±0.1°		DWG NO. MA-OEM-33	REV A
SCALE: 1:2	SHEET 1 OF 1	A3	